



GAI-TRONICS® CORPORATION
A HUBBELL COMPANY

Volume Level Control Receiver Assembly (24 V DC) Replacement Kit

MODEL 12250-004

Confidentiality Notice

This manual is provided solely as an operational, installation, and maintenance guide and contains sensitive business and technical information that is confidential and proprietary to GAI-Tronics. GAI-Tronics retains all intellectual property and other rights in or to the information contained herein, and such information may only be used in connection with the operation of your GAI-Tronics product or system. This manual may not be disclosed in any form, in whole or in part, directly or indirectly, to any third party.

General Information

This kit is for use on the following 24 V dc handset/speaker amplifiers and speaker amplifiers with the corresponding printed circuit board assembly (PCBA):

24 V DC Amplifiers Model No.	PCBA No.
701-103	69701-102
701-203	69701-005
701-207	69701-011
701-307	69701-015
713-102	69713-202
723-003	69723-202
751-002	69701-012

NOTES:

1. This volume level control (VLC) kit can be used on older GAI-Tronics amplifiers (not listed); however, it is not recommended. Amplifier models not included on the list on page 1 have been obsolete since the 1987–1989 time period, and replacement parts for them are available on a limited basis. If the VLC is to be installed in a station with an older amplifier, replace amplifier with a listed model (possibly switching amplifiers from a location that does not require a VLC and has a newer, listed amplifier).

2. All agency approvals are nullified with the addition of VLC assembly, if not factory installed.

This kit includes the following components:

Qty	Description
1	Volume Level Control Receiver Assembly (for 24 V dc applications only)
2	Screw, 6-32 × ¼-inch PHMS
1	Resistor, ¼-watt, 5%
1	Template (for locating drilling holes)
1	Tie Wrap

NOTE: All items contained in this kit may not be required in all installations.

Installation

Models 701-103, 701-203, 701-207, 701-307, 713-102, 723-003 and 751-002

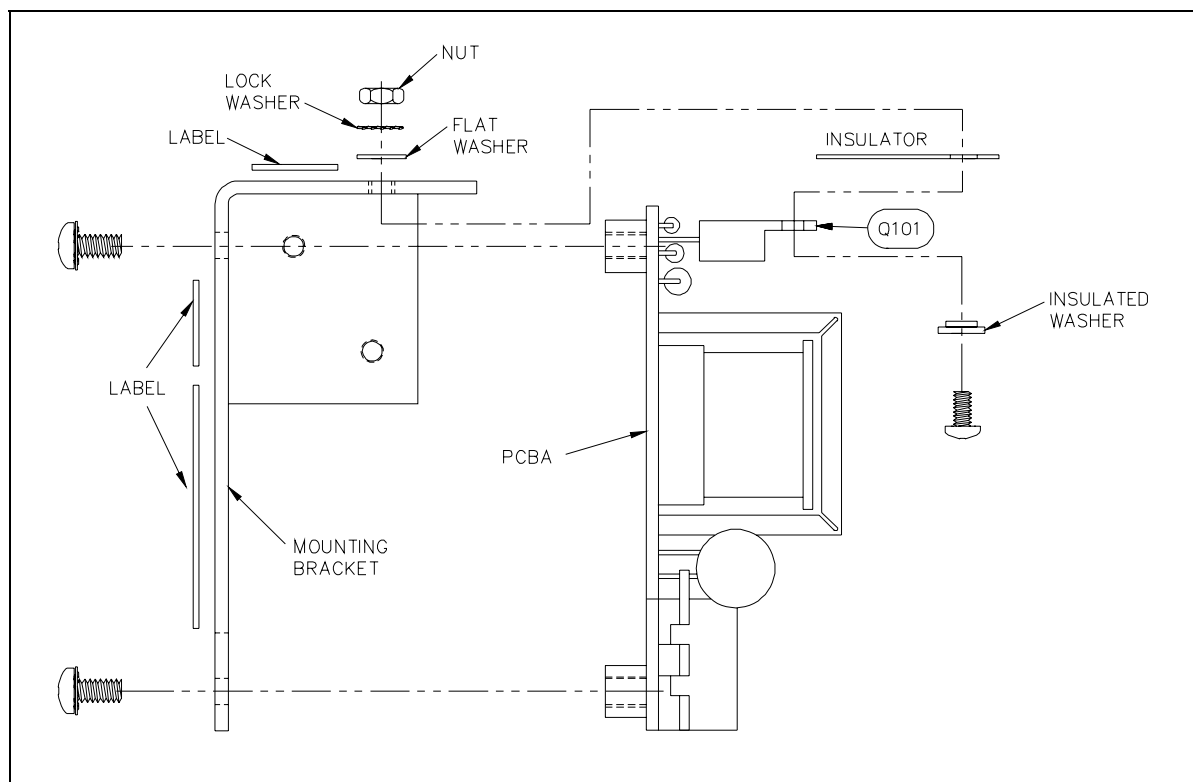

Figure 1. VLC Assembly

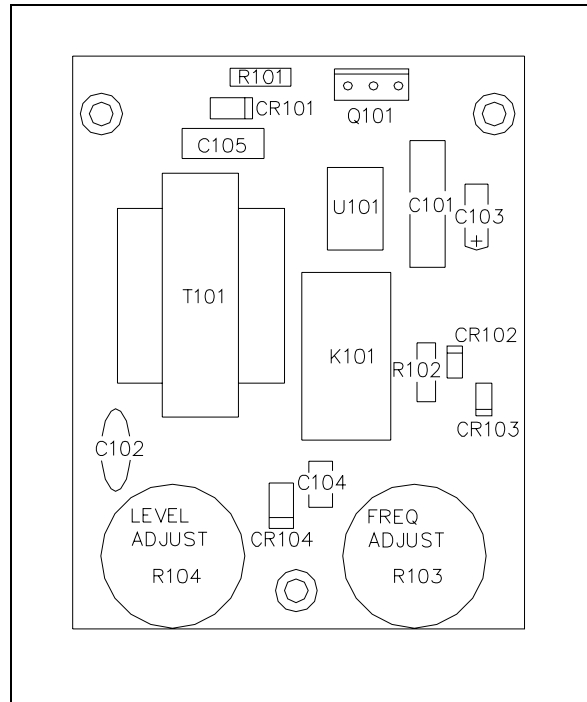

Figure 2. VLC PCBA Component Location

Disassembly

1. Loosen the four front panel screws, and remove the amplifier from the enclosure.
2. Loosen the four screws on the side, and slide the chassis to remove the front panel. If the unit does not contain a handset, immediately set the front panel aside.
3. If the unit contains a handset, disconnect the wires at the printed circuit board assembly (PCBA), and set the front panel aside. Note the wire color and location prior to removal to allow for easier re-assembly.

NOTE: Skip Step 4 if the amplifier does not have a chassis-mounted transformer.

4. Place the chassis on the bench with the connector toward you. Disconnect the transformer by removing the two mounting screws. Disconnect the 6-pin Molex connector from the PCBA, and set it aside.



CAUTION

Removal of the PCBA before drilling is advisable.

5. Loosen the two screws holding the amphenol connector to the chassis.
6. Using pliers, press the plastic standoffs through the back of the chassis to remove the PCBA. Set the PCBA aside. Be careful not to break the standoffs when pushing them through.

7. Turn the chassis over. With the connector opening at the top of the chassis, place the template along the right edge of the chassis as shown on the diagram. Refer to Figure 3 below.

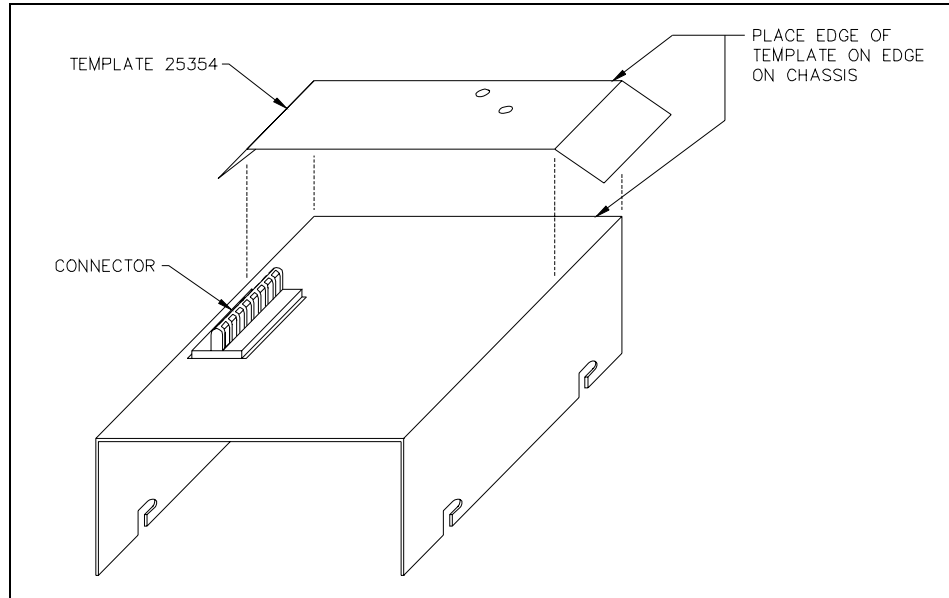

Figure 3. Template 25354

8. With the template in place, carefully center punch the holes. Drill two $\frac{5}{32}$ -inch holes, and deburr the opposite side.
9. Orient the PCBA with the connector at the top.

NOTE: Step 10 is applicable for models that have R14 installed in the off-hook detection circuitry. See applicable models and associated boards in Figures 4A, 4B, and 4C for listing.

10. Replace R14 by de-soldering and removing the old resistor (10,000 ohm, $\frac{1}{4}$ watt, 5% [brown-black-orange-gold]). Insert the 4,700-ohm, $\frac{1}{4}$ -watt, 5% (yellow-violet-red-gold) resistor provided in this kit into the PCBA, and re-solder it. Trim the resistor leads to avoid possible shorts after re-assembly. See Figure 4.
11. De-solder and remove the W-3 jumper (0-ohm resistor) between E25 and E26. See applicable model in Figure 4.
12. Remove solder from the following pads with a solder remover tool. If a solder remover tool is not available, use a solder wick to remove the solder: E23, E24, E25, E26, E28, and E31.

NOTE: P1 connections do not require removing the solder. Heat the pin with the soldering iron, and push the wire in.

Re-assembly

13. Wire connections from the VLC are to be soldered to the PCBA. See applicable model and PC board in Figure 4.

NOTE: "E" locations may vary slightly from what is shown in Figure 4; however, the connections remain the same.

- Black E28
- Red E31
- Brown E24
- White E26
- Green E23
- Yellow E25

Red/Blue P1 (L1) Refer to applicable model and PC board in Figure 4.

Blue/Red P1 (L2) Refer to applicable model and PC board in Figure 4.

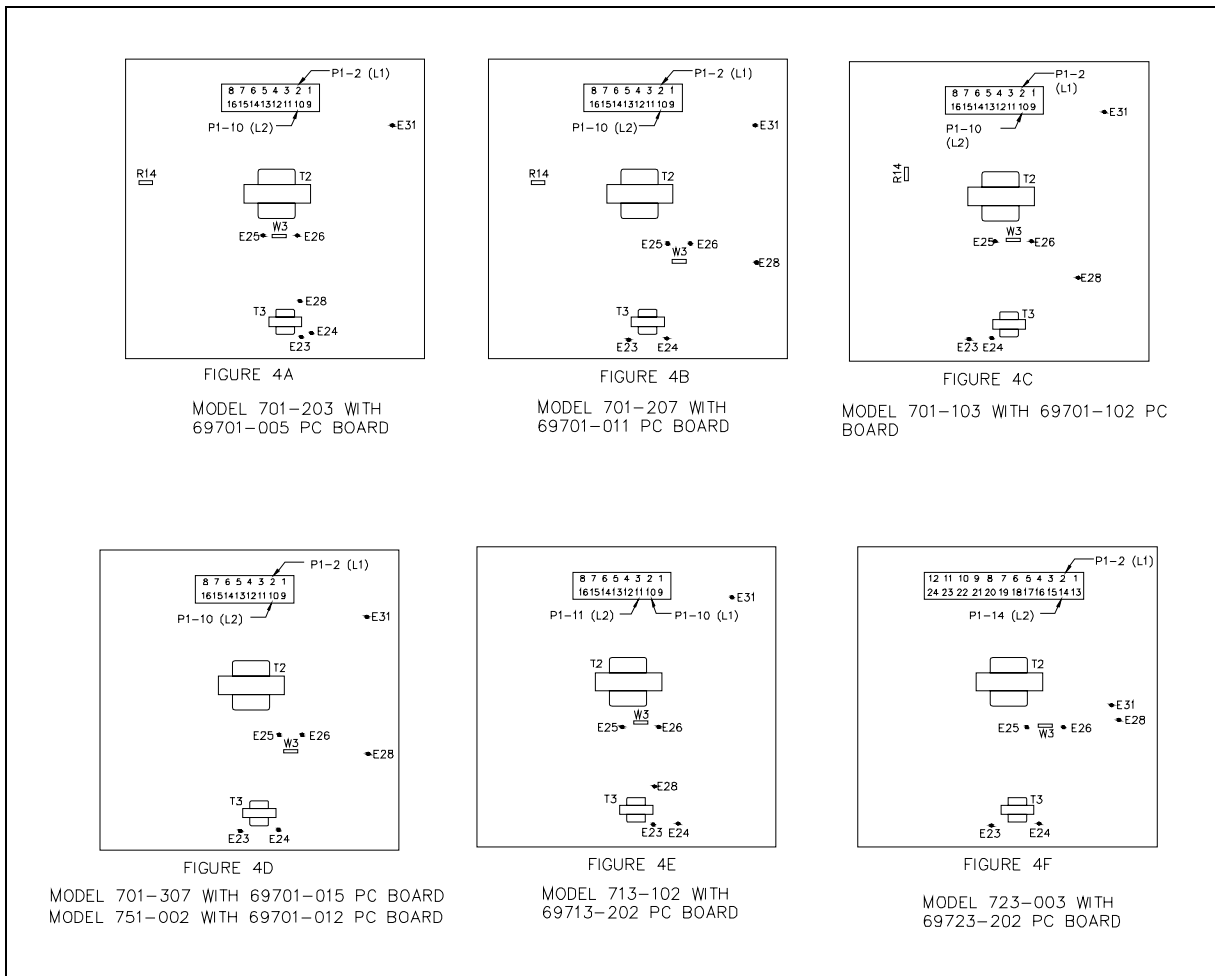

Figure 4. Wiring Details

14. Replace the PCBA by inserting the amphenol connector in the chassis opening and pressing it into place. Push the standoffs through the chassis, and retighten the two screws holding the amphenol connector to the chassis.

15. Connect the purple wire from the front panel to E7 on the PCBA, if applicable. On PCBA assembly 69701-015, connect one of the magnetic reed hookswitch wires from the front panel to E7 on the PCBA. Connect the other wire to E5 on the PCBA. On PCBA assemblies, (69701-011 and 69701-015) ensure that the clip is bent inward to the board to prevent shorting any adjacent component.
16. Place the VLC mounting flange between the chassis and the PCBA, and align it with the holes. Insert two 6-32 × 1/4-inch screws, and tighten them. Recheck the purple wire at E7 of the PCBA for clearance from adjacent components, if applicable.
17. If the unit has a handset, pick up the front panel, and position it so the remaining handset wires can be hooked up to the PCBA. For ease of installation, the handset wires are color coded as follows:

White	E1
Black	E2
Green	E3
Red	E4
Yellow	E5
Blue	E6
18. Reinstall the transformer on the chassis using the 2 screws removed previously. The blue and brown wires on the transformer should be facing up, or the chassis will not close.
19. Reconnect the 6-pin Molex connector to the PCBA.
20. Dress the VLC wires, and secure them with the tie wrap included in this kit.
21. Mount the front panel to the chassis, and tighten the 4 screws.
22. Plug the amplifier into the enclosure, and tighten the 4 screws.

NOTES:

1. Speaker adjustment for normal operation remains under the nameplate on the front panel and does not change with the addition of the VLC. The speaker adjustment for the VLC is factory set and can be varied by adjusting the level potentiometer on the VLC assembly.
2. When an alarm is broadcast and is accompanied by a VLC (50 kHz) signal on the page line, it triggers the volume on the Page/Party[®] VLC amplifier to increase. GAI-Tronics Model 800 and 1200 Series cone speaker assemblies are normally used for indoor applications with low ambient noise, such as offices, corridors, and control rooms. These speakers have a manual, wall-mounted remote volume level control.

When these speakers are powered by a Page/Party[®] VLC amplifier, and the volume level is manually turned down using the wall-mounted remote volume level control, the signal that increases the volume on the VLC amplifier will not bypass the manual setting. These speakers remain “turned down,” regardless of the output signal of the amplifier, and the alarm broadcast level does NOT increase on the cone speaker assemblies.

The Model 800 and 1200 Series speakers can be used in emergency notification systems; however, we suggest that the customer NOT install the wall-mounted remote volume level control for this type of application.

3. DO NOT READJUST the frequency potentiometer on the VLC assembly.

Warranty

Equipment. GAI-Tronics warrants for a period of one (1) year from the date of shipment, that any GAI-Tronics equipment supplied hereunder shall be free of defects in material and workmanship, shall comply with the then-current product specifications and product literature, and if applicable, shall be fit for the purpose specified in the agreed-upon quotation or proposal document. If (a) Seller's goods prove to be defective in workmanship and/or material under normal and proper usage, or unfit for the purpose specified and agreed upon, and (b) Buyer's claim is made within the warranty period set forth above, Buyer may return such goods to GAI-Tronics' nearest depot repair facility, freight prepaid, at which time they will be repaired or replaced, at Seller's option, without charge to Buyer. Repair or replacement shall be Buyer's sole and exclusive remedy. The warranty period on any repaired or replacement equipment shall be the greater of the ninety (90) day repair warranty or one (1) year from the date the original equipment was shipped. In no event shall GAI-Tronics warranty obligations with respect to equipment exceed 100% of the total cost of the equipment supplied hereunder. Buyer may also be entitled to the manufacturer's warranty on any third-party goods supplied by GAI-Tronics hereunder. The applicability of any such third-party warranty will be determined by GAI-Tronics.

Services. Any services GAI-Tronics provides hereunder, whether directly or through subcontractors, shall be performed in accordance with the standard of care with which such services are normally provided in the industry. If the services fail to meet the applicable industry standard, GAI-Tronics will re-perform such services at no cost to buyer to correct said deficiency to Company's satisfaction provided any and all issues are identified prior to the demobilization of the Contractor's personnel from the work site. Re-performance of services shall be Buyer's sole and exclusive remedy, and in no event shall GAI-Tronics warranty obligations with respect to services exceed 100% of the total cost of the services provided hereunder.

Warranty Periods. Every claim by Buyer alleging a defect in the goods and/or services provided hereunder shall be deemed waived unless such claim is made in writing within the applicable warranty periods as set forth above. Provided, however, that if the defect complained of is latent and not discoverable within the above warranty periods, every claim arising on account of such latent defect shall be deemed waived unless it is made in writing within a reasonable time after such latent defect is or should have been discovered by Buyer.

Limitations / Exclusions. The warranties herein shall not apply to, and GAI-Tronics shall not be responsible for, any damage to the goods or failure of the services supplied hereunder, to the extent caused by Buyer's neglect, failure to follow operational and maintenance procedures provided with the equipment, or the use of technicians not specifically authorized by GAI-Tronics to maintain or service the equipment. **THE WARRANTIES AND REMEDIES CONTAINED HEREIN ARE IN LIEU OF AND EXCLUDE ALL OTHER WARRANTIES AND REMEDIES, WHETHER EXPRESS OR IMPLIED BY OPERATION OF LAW OR OTHERWISE, INCLUDING ANY WARRANTIES OF MERCHANTABILITY OR FITNESS FOR A PARTICULAR PURPOSE.**

Return Policy

If the equipment requires service, contact your Regional Service Center for a return authorization number (RA#). Equipment should be shipped prepaid to GAI-Tronics with a return authorization number and a purchase order number. If the equipment is under warranty, repairs or a replacement will be made in accordance with the warranty policy set forth above. Please include a written explanation of all defects to assist our technicians in their troubleshooting efforts.

Call 800-492-1212 (inside the USA) or 610-777-1374 (outside the USA) for help identifying the Regional Service Center closest to you.